



Devonshire Way, Harrogate, HG1 4BH

- NO ONWARD CHAIN
- Driveway with off-road parking
- Welcoming entrance hallway leading into the home
- Separate, well-designed kitchen with practical layout
- Early viewing highly recommended
- Three-bedroom semi-detached family home
- French doors opening onto a private rear garden
- Garage providing additional storage
- Located close to amenities and public transport links
- Council Tax Band C

Guide Price £262,500



Devonshire Way, Harrogate, HG1 4BH

DESCRIPTION

NO ONWARD CHAIN. Located on Devonshire Way, this delightful three-bedroom semi-detached house presents an excellent opportunity for families and first-time buyers alike. The property boasts two spacious double bedrooms and a comfortable single bedroom, providing ample space for relaxation and rest.

Upon entering into the hallway, you will find a welcoming reception room and a separate kitchen, designed for both functionality and style. The kitchen features French doors that open out onto a private back garden, creating a perfect setting for outdoor entertaining or simply enjoying the fresh air. The garden includes a lovely patio area, ideal for placing outdoor furniture and enjoying al fresco dining during the warmer months.

For added convenience, the property includes a garage, providing extra storage space, as well as a driveway that allows for off-road parking. This feature is particularly beneficial in a bustling area like Harrogate, where parking can often be a challenge.

The location is superb, with easy access to local amenities and public transport links, making it a practical choice for those commuting or seeking the vibrant lifestyle that Harrogate has to offer. This property is not just a house; it is a home waiting to be filled with memories. Do not miss the chance to make this charming residence your own.

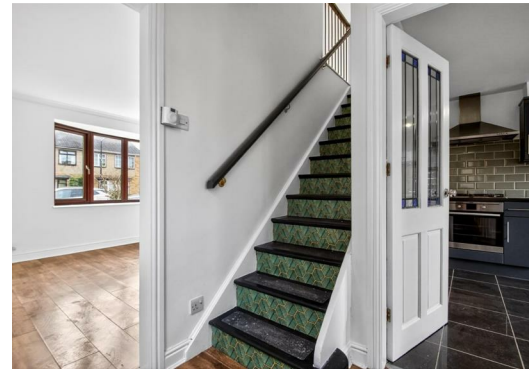

EPC
Energy rating D
This property produces 4.0 tonnes of CO2

Material Information - Harrogate
Tenure Type: Freehold
Council Tax Banding: C

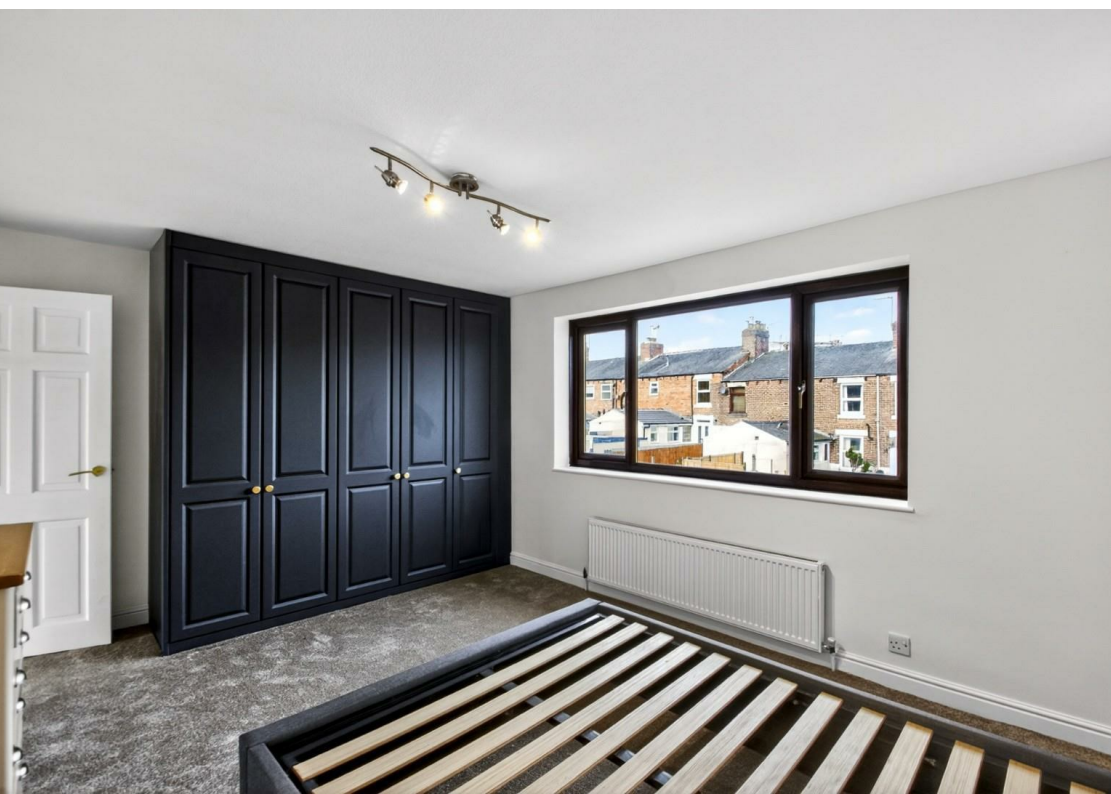

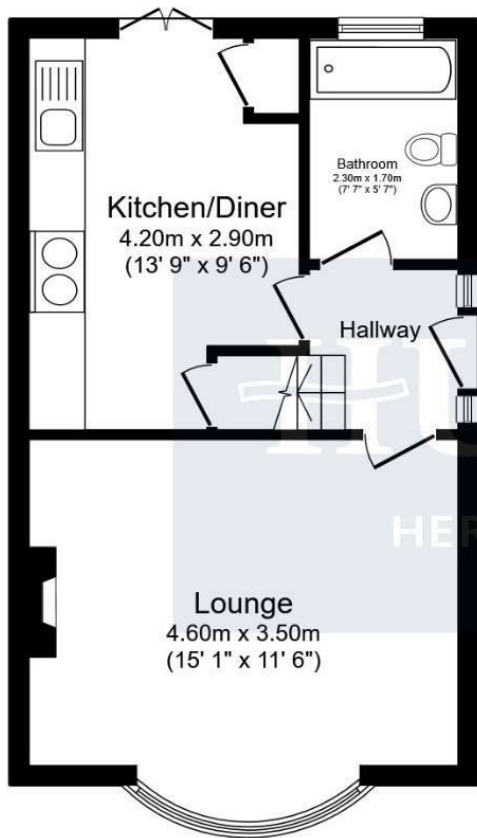

Ground Floor

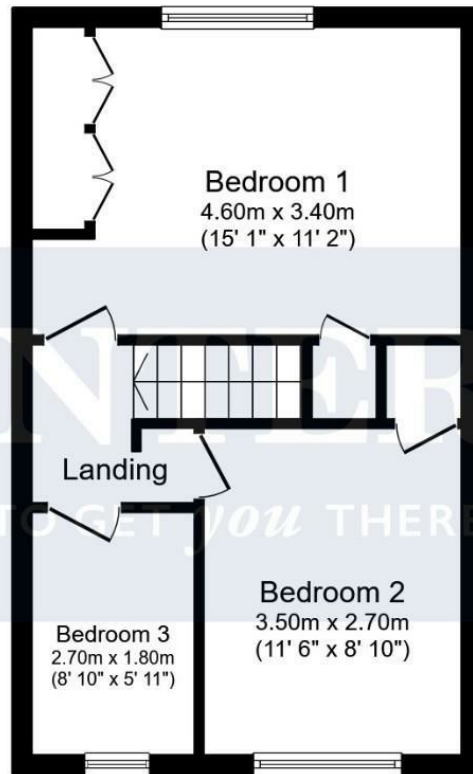

First Floor

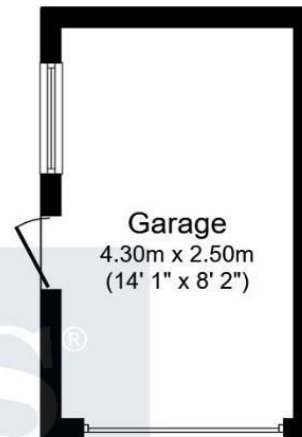

Garage

Total floor area 83.4 sq.m. (897 sq.ft.) approx

This floor plan is for illustrative purposes only. It is not drawn to scale. Any measurements, floor areas (including any total floor area), openings and orientation are approximate. No details are guaranteed, they cannot be relied upon for any purpose and they do not form part of any agreement. No liability is taken for any error, omission or misstatement. A party must rely upon its own inspection(s). Powered by propertybox.io

Viewings

Please contact harrogate@hunters.com, if you wish to arrange a viewing appointment for this property or require further information.

Valuations

For a valuation of your property, please email the team with your property details, contact information and the times you are available.

ENERGY PERFORMANCE CERTIFICATE

The energy efficiency rating is a measure of the overall efficacy of a home. The higher the rating the more energy efficient the home is and the lower the fuel bills will be.

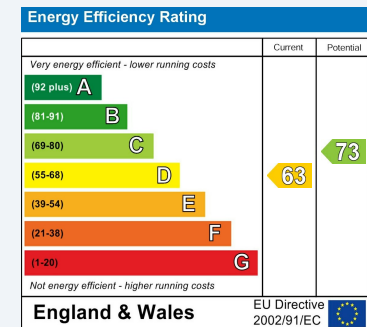

These particulars are intended to give a fair and reliable description of the property but no responsibility for any inaccuracy or error can be accepted and do not constitute an offer or contract. We have not tested any services or appliances (including central heating if fitted) referred to in these particulars and the purchasers are advised to satisfy themselves as to the working order and condition. If a property is unoccupied at any time there may be reconnection charges for any switched off/disconnected or drained services or appliances - All measurements are approximate.

THINKING OF SELLING? If you are thinking of selling your home or just curious to discover the value of your property, Hunters would be pleased to provide free, no obligation sales and marketing advice. Even if your home is outside the area covered by our local offices we can arrange a Market Appraisal through our national network of Hunters estate agents.



Regents House, 13-15 Albert Street, Harrogate, HG1 1JX
 Tel: 01423 536222 Email: harrogate@hunters.com <https://www.hunters.com>

